

## WARNER GEAR T5wc 5 Speed: FORD

### COMPLETE ASSEMBLIES: MUSTANG

**FOUR CYLINDER:**

3.50/2.14/1.39/1.00/0.78	(1985-86)	E5ZR-7003EA	13-52-000-116
<i>NOTE: This ONE (1) assembly for 'SVO' 2.3L turbo.</i>			
3.97/2.34/1.46/1.00/0.85	(1987)		13-52-000-154
3.97/2.34/1.46/1.00/0.79	(1987-88)	E7ZR-7003AA	13-52-000-162
3.97/2.34/1.46/1.00/0.79	(1989-90)	E9ZR-7003AA	13-52-000-194
3.97/2.34/1.46/1.00/0.79	(1991)	F1ZR-7003AA	13-52-000-207
3.97/2.34/1.46/1.00/0.79	(1992-93)	F2ZR-7003BA	13-52-000-209

*NOTE: These FIVE (5) assemblies for 2.3L NA.*

**SIX CYLINDER:**

3.35/1.93/1.29/1.00/0.73	(1994)		13-52-000-220
3.35/1.93/1.29/1.00/0.73	(1995)		13-52-000-236
3.35/1.93/1.29/1.00/0.73	(1994-97)		13-52-000-238
<i>NOTE: These THREE (3) assemblies for 3.8L NA, mechanical speedometer.</i>			
3.75/2.19/1.47/1.00/	(1999)		13-52-000-260

*NOTE: These TWO (2) assemblies for 3.8L NA, magnetic speedometer.*

**EIGHT CYLINDER:**

3.35/1.93/1.29/1.00/0.68	(1985)	E5ZR-7003FA	13-52-000-126
3.35/1.93/1.29/1.00/0.68	(1986)	E6ZR-7003FA	13-52-000-141
3.35/1.93/1.29/1.00/0.68	(1986)	E6ZR-7003FB	13-52-000-165
3.35/1.93/1.29/1.00/0.68	(1986-89)		13-52-000-169
3.35/1.99/1.33/1.00/0.68	(1990-91)		13-52-000-199
3.35/1.99/1.33/1.00/0.68	(1992-93)		13-52-000-208
3.35/1.99/1.33/1.00/0.68	(1994)		13-52-000-219
3.35/1.99/1.33/1.00/0.68	(1994-95)		13-52-000-246
<i>NOTE: These EIGHT (8) assemblies for standard 5.0L. Loose roller mainshaft pilot.</i>			
3.35/1.99/1.33/1.00/0.68	(1993)		13-52-000-218
3.35/1.99/1.33/1.00/0.68	(1994-95)		13-52-000-242

*NOTE: These TWO (2) assemblies for 'Cobra' 5.0L. Tapered bearing mainshaft pilot.*

**TO BE ALLOCATED:**

all			TTET 1544
all			TTET 1751
all			TTET 1752
all			TTET 1798
all			TTET 1955
CSC fixed			TTET 2071
all		3R3Z-7003BC	TTET 2141
RSC slip		3R3Z-7003DA	TTET 4782
CSC fixed		6R3Z-7003A	TTET 5758
CSC fixed		7R3Z-7003K	TTET 6884

### COMPLETE ASSEMBLIES: THUNDERBIRD

4.03/2.37/1.49/1.00/0.81	(1985-86)	E5SR-7003AA	13-52-000-114
3.97/2.34/1.46/1.00/0.79	(1987)	E7SR-7003AA	13-52-000-155

*NOTE: These TWO (2) assemblies for 2.3L 'turbocoupe'.*

## WARNER GEAR T5wc 5 Speed: FORD

### COMPLETE ASSEMBLIES: MOTORSPORT

2.95/1.94/1.34/1.00/0.63	(1979-93)	M-7003A	13-52-000-115
2.95/1.94/1.34/1.00/0.63	(1979-93)	E4ZM-7003A	13-52-000-200
2.95/1.94/1.34/1.00/0.63	(1979-93)	M-7003X	13-52-000-227
2.95/1.94/1.34/1.00/0.63	(1979-93)	M-7003Z	13-86-000-249

### COMPLETE ASSEMBLIES: AFTERMARKET

2.95/1.94/1.34/1.00/0.80	(1979-93)		13-52-000-202
2.95/1.94/1.34/1.00/0.80	(1979-93)		13-52-000-225
2.95/1.94/1.34/1.00/0.63	(1979-93)		13-52-000-251

*NOTE: These THREE (3) assemblies with loose roller mainshaft pilot.*

### SERVICE KITS

<b>K1</b>	<b>Overhaul Kit</b>			
	slip yoke: Thunderbird 2.3L turbo	(1985-87)	NSS	OH52A
	slip yoke: except above	(1985-03)	NSS	OH52
	fixed yoke	(2004- )	NSS	OH52B
<b>K1-1</b>	<b>Bearing/Oilseal Kit</b>			
	slip yoke: Thunderbird 2.3L turbo	(1985-87)	NSS	BK52A
	slip yoke: except above	(1985-03)	NSS	BK52
	fixed yoke	(2004- )	NSS	BK52B
	<i>NOTE: Tapered bearings and oilseals for ONE (1) transmission.</i>			
<b>K1-2</b>	<b>Shim Kit</b>			
	Thunderbird 2.3L turbo	(1985-87)	NSS	SH52A
	except above	(1985- )	NSS	SH52
	<i>NOTE: Tapered bearing shims for ONE (1) transmission.</i>			
<b>K1-3</b>	<b>Synchronizer Kit</b>			
	all	(1985- )	NSS	YN52
	<i>NOTE: Synchronizer rings, struts, springs and pads for ONE (1) transmission.</i>			
<b>K1-4</b>	<b>Small Parts Kit</b>			
	all	(1985- )	NSS	SP52
	<i>NOTE: Needle bearings, washers, and snaprings for ONE (1) transmission.</i>			

### GROUP A: MAINSHAFT AND EXTENSION ASSY

<b>A1</b>	<b>Flange Retaining Nut</b>			
	fixed flange	(2004- )	4R3Z-7B340AA	19-00-149-002
<b>A2</b>	<b>Flange Retaining Washer</b>			
	fixed flange	(2004- )	4R3Z-7119A	19-00-047-005
<b>A3</b>	<b>Flange</b>			
	fixed flange	(2004- )		TTBD 2172
<b>A4</b>	<b>Mainshaft Spline Snapping</b>			
	slip yoke	(1985-03)	E3ZZ-7064A	10-00-139-032

**WARNER GEAR T5wc 5 Speed: FORD**

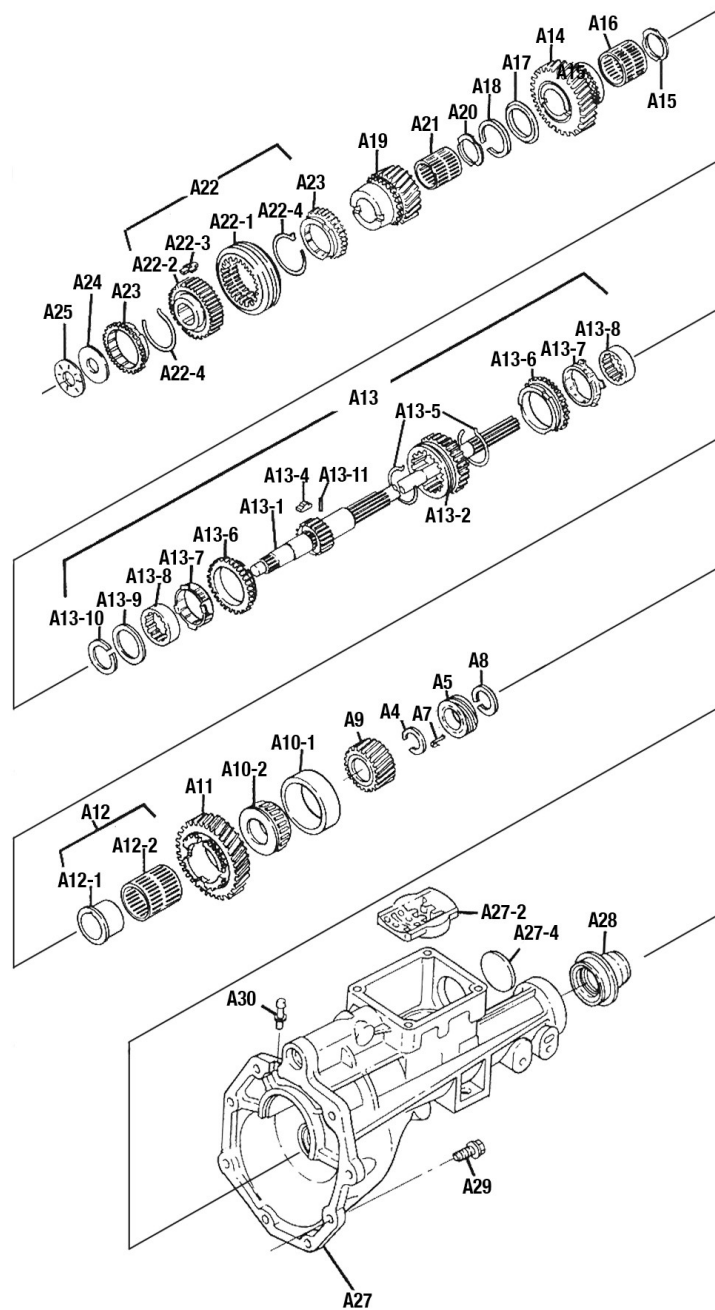

## WARNER GEAR T5wc 5 Speed: FORD

A5	Speedometer Circle Gear			
	R6T black nylon	(1985-03)	E3ZZ-17285B	13-52-110-004
	R7T yellow nylon	(1985-03)	E3ZZ-17285A	13-52-110-005
	R8T light blue nylon	(1985-03)	F0ZZ-17285A	13-52-110-011
A6	Speedometer Rotor S12T steel	(1999- )	XR3Z-7H150AA	13-52-110-018
A7	Speedometer Circle Gear Fasteners clip	(1985-03)	E3TZ-17B336A	13-90-056-002
A8	Mainshaft 5 <sup>th</sup> Gear Snapping all		E3TZ-7064A	10-00-139-032
A9	Mainshaft 5 <sup>th</sup> Gear			
	L27-s28T: 4 cylinder T'bird	(1985-86)	E5ZZ-7K316A	13-52-070-022
	L25-s28T: 4 cylinder Mustang	(1985-86)	E5ZZ-7K316B	13-52-070-027
	L27-s28T: 4 cylinder	(1987-93)	E5ZZ-7K316A	13-52-070-022
	L25-s28T: 6 cylinder	(1994-03)	E5ZZ-7K316B	13-52-070-027
	Lxx-sxxT: 6 cylinder	(2004- )	4R3Z-7M005CA	TTEN 4761
	L33-s28T: 8 cylinder 2.95 low			13-52-070-046
	L27-s28T: 8 cylinder 3.35 low	(1985-93)	E5ZZ-7K316A	13-52-070-022
A10	Mainshaft Bearing Assy Timken #25821-25877A			
A10-1	Mainshaft Bearing Cup Timken #25821		C6TZ-7169A	13-51-133-004
A10-2	Mainshaft Bearing Cone Timken #25877A		C3TZ-1216B	13-51-133-003
A11	Mainshaft 1 <sup>st</sup> Gear			
	L32-s20(30)T: 4 cylinder T'bird	(1985-86)	E5SZ-7100A	13-52-080-031
	L33-s20(30)T: 4 cylinder Mustang	(1985-86)	E5ZZ-7100B	13-52-080-032
	L32-s20(30)T: 4 cylinder	(1987-93)	E7ZZ-7100A	13-52-080-112
	L34-s20(30)T: 6 cylinder	(1994-03)	E5ZZ-7100A	13-52-080-030
	<i>NOTE: This ONE (1) gear has an xx.xx degree helix angle.</i>			
	L34-s20(30)T: 6 cylinder	(2004- )	4R3Z-7100A	13-52-080-154
<i>NOTE: This ONE (1) gear has an xx.xx degree helix angle.</i>				
	L32-s20(30)T: 8 cylinder 2.95 low		E5SZ-7100A	13-52-080-031
	L34-s20(30)T: 8 cylinder 3.35 low	(1985-95)	E5ZZ-7100A	13-52-080-030
A12	Mainshaft 1 <sup>st</sup> Gear Bushing Assy all			13-52-603-006
A12-1	Mainshaft 1 <sup>st</sup> Gear Bushing all		E5ZZ-7173A	13-52-103-003
A12-2	Mainshaft 1 <sup>st</sup> Gear Bearing all		E5ZZ-7127A	13-52-132-006
A13	Mainshaft Assy slip yoke	(1993-95)	F3ZZ-7061A	13-52-671-111
	<i>NOTE: This ONE (1) assembly with tapered bearing pilot.</i>			
	slip yoke	(1985-99)	F5ZZ-7061A	13-52-671-085
	<i>NOTE: These TWO (2) assemblies with mechanical speedometer.</i>			
	slip yoke	(1999-03)	XR3Z-7061AA	13-52-671-129
fixed yoke	(2004- )		TTEF 2155	
<i>NOTE: These TWO (2) assemblies with magnetic speedometer.</i>				
<i>NOTE: These THREE (3) assemblies with needle bearing pilot.</i>				

## WARNER GEAR T5wc 5 Speed: FORD

A13-1	Mainshaft all		NSS	NSS
A13-2	Reverse Gear all		NSS	13-52-070-042
A13-3	Hub all		NSS	NSS
A13-4	Strut all	req. 3	E5ZZ-7A044A	13-52-093-001
A13-5	Spring all	req. 2	E5ZZ-7109A	13-52-156-018
A13-6	Mainshaft 1 <sup>st</sup> /2 <sup>nd</sup> Synchronizer Ring (Outer) s30T: steel	req. 2	E5ZZ-7107A	13-52-091-001
A13-7	Mainshaft 1 <sup>st</sup> /2 <sup>nd</sup> Synchronizer Ring (Center) lined ring w/ 4 tangs	req. 2	E5ZZ-7174A	13-52-525-001
A13-8	Mainshaft 1 <sup>st</sup> /2 <sup>nd</sup> Synchronizer Ring (Inner) s18T: cone	req. 2	E5ZZ-7175A	13-52-025-001
A13-9	Thrust Washer all		E5ZZ-7117A	13-52-193-002
A13-10	Retaining Snapping all		E5ZZ-7160A	13-52-139-005
A13-11	Retaining Pin all		E5ZZ-7K218A	13-52-043-006
A14	Mainshaft 2 <sup>nd</sup> Gear			
	L31-s20(30)T: 4 cylinder	(1985-86)	E5ZZ-7102A	13-52-080-037
	L31-s20(30)T: 4 cylinder	(1987-93)	E7ZZ-7102A	13-52-080-113
	L30-s20(30)T: 6 cylinder	(1994-03)	E5ZZ-7102B	13-52-080-060
	L37-s20(30)T: 6 cylinder	(2004- )	4R3Z-7102A	13-52-080-155
	L33-s20(30)T: 8 cylinder 2.95 low			13-52-080-028
	L30-s20(30)T: 8 cylinder 3.35 low	(1985-89)	E5ZZ-7102B	13-52-080-060
	L31-s20(30)T: 8 cylinder 3.35 low	(1990-95)	F0ZZ-7102A	13-52-080-152
A15	Mainshaft 2 <sup>nd</sup> Gear Bearing Spacer all		E5ZZ-7728A	13-52-053-003
A16	Mainshaft 2 <sup>nd</sup> Gear Bearing all		E5ZZ-7B369A	13-52-132-002
A17	Mainshaft 2 <sup>nd</sup> Gear Thrust Washer all		E5ZZ-7119A	13-52-193-004
A18	Mainshaft 2 <sup>nd</sup> Gear Thrust Washer Snapping all		E7ZZ-7064A	13-00-139-028
A19	Mainshaft 3 <sup>rd</sup> Gear			
	L27-s30T: 4 cylinder T'bird	(1985-86)	E5ZZ-7B340B	13-52-080-046
	L27-s30T: 4 cylinder Mustang	(1985-86)	E5ZZ-7B340A	13-52-080-044
	L26-s30T: 4 cylinder	(1987-93)	E7ZZ-7B340A	13-52-080-115
	L27-s30T: 6 cylinder	(1994-03)	E6ZZ-7B340A	13-52-080-044
	L29-s30T: 6 cylinder	(2004- )	4R3Z-7B340A	13-52-080-156
	L30-s30T: 8 cylinder 2.95 low			13-52-083-002
	L27-s30T: 8 cylinder 3.35 low	(1985-89)	E5ZZ-7B340A	13-52-080-044
	L26-s30T: 8 cylinder 3.35 low	(1990-95)	F0ZZ-7B340A	13-52-080-151
A20	Mainshaft 3 <sup>rd</sup> Gear Bearing Spacer all		E5ZZ-7B320A	13-52-053-004

## WARNER GEAR T5wc 5 Speed: FORD

<b>A21</b>	<b>Mainshaft 3<sup>rd</sup> Gear Bearing</b> all		<b>E5ZZ-7B369B</b>	<b>13-52-132-003</b>
<b>A22</b>	<b>Mainshaft 3<sup>rd</sup>/4<sup>th</sup> Synchronizer Assy</b> all		<b>E5ZZ-7124A</b>	<b>13-52-590-011</b>
	<b>A22-1 Clutch</b> all		<b>NSS</b>	<b>NSS</b>
	<b>A22-2 Hub</b> all		<b>NSS</b>	<b>NSS</b>
	<b>A22-3 Strut</b> all	<b>req. 3</b>	<b>E4ZZ-7A044A</b>	<b>13-51-093-001</b>
	<b>A22-4 Spring</b> all	<b>req. 2</b>	<b>E5ZZ-7109A</b>	<b>13-52-156-018</b>
<b>A23</b>	<b>Mainshaft 3<sup>rd</sup>/4<sup>th</sup> Synchronizer Ring</b> S30T lined	<b>req. 2</b>	<b>E5ZZ-7107C</b>	<b>13-52-591-003</b>
<b>A24</b>	<b>Mainshaft Thrust Race</b> used w/ needle bearing pilot	<b>(1985-93)</b>	<b>E3ZZ-7D235A</b>	<b>13-51-018-005</b>
<b>A25</b>	<b>Mainshaft Thrust Bearing</b> used w/ needle bearing pilot	<b>(1985-93)</b>	<b>E3ZZ-7D234A</b>	<b>13-51-132-004</b>
<b>A26</b>	<b>Mainshaft 3<sup>rd</sup>/4<sup>th</sup> Synchronizer Snapping</b> used w/ tapered bearing pilot	<b>(1993-95)</b>	<b>F3ZZ-7030A</b>	<b>13-00-139-019</b>
<b>A27</b>	<b>Extension Assy</b> #13-81-066-939	<b>(1985-99)</b>	<b>F2ZZ-7A039A</b>	<b>13-52-566-081</b>
	<i>NOTE: This ONE (1) Extension Assembly used with mechanical speedometer.</i>			
	slip yoke	<b>(1999-03)</b>	<b>XR3Z-7A039AA</b>	<b>13-52-566-107</b>
	fixed yoke	<b>(2004- )</b>		<b>TTEP 2164</b>
	<i>NOTE: These TWO (2) Extension Assemblies used with magnetic speedometer.</i>			
	<b>A27-1 Extension</b> all		<b>NSS</b>	<b>NSS</b>
	<b>A27-2 Shift Pattern Guide</b> all			<b>13-52-014-005</b>
	<b>A27-3 Mainshaft Bushing</b> slip yoke		<b>B3TZ-7A034B</b>	<b>10-00-127-017</b>
	<i>NOTE: Bushing must be reamed to size after assembly.</i>			
	<b>A27-4 Cup Plug</b> slip yoke		<b>E3ZZ-7K381A</b>	<b>10-00-113-010</b>
	<b>A27-5 Mainshaft Extension Bearing</b> fixed yoke	<b>(2004- )</b>		<b>TTBA 2165</b>
	<b>A27-6 Mainshaft Extension Bearing Snapping</b> fixed yoke	<b>(2004- )</b>	<b>4R3Z-7109A</b>	<b>TTMS 2166</b>
	<b>A27-7 Selector Shaft Oilseal</b> fixed yoke	<b>(2004- )</b>		<b>13-00-044-021</b>
<b>A28</b>	<b>Mainshaft Oilseal</b> slip yoke	<b>(1985-93)</b>	<b>E2DZ-7052A</b>	<b>13-00-044-012</b>
	slip yoke	<b>(1994-03)</b>	<b>F4ZZ-7052A</b>	<b>13-00-044-019</b>
	fixed yoke	<b>(2004- )</b>	<b>4R3Z-7052AA</b>	<b>TTSj 2122</b>
<b>A29</b>	<b>Extension Fasteners</b> bolt	<b>req.8</b>	<b>E805600S</b>	<b>13-00-183-014</b>

## WARNER GEAR T5wc 5 Speed: FORD

<b>A30 Breather (Assy)</b>			
all		01A-7034	T94-95
fixed yoke		F6ZZ-7034A	13-00-072-005
<b>A30-1 Breather</b>			
fixed yoke		NSS	10-00-072-004
<b>A30-2 O-Ring</b>			
fixed yoke			4804B

## GROUP B: MAINDRIVE AND RETAINER

<b>B1 Mainshaft Pilot Rollers</b>			
Torrington #C417Q	req.15	C3AZ-7118A	13-32-131-001
<b>B2 Mainshaft Pilot Roller Spacer</b>			
all	(1992- )	F2ZZ-7L357A	13-52-053-005
<b>B3 Mainshaft Pilot Bearing Assy</b>			
Timken #LM11710-LM11749	(1993-95)		LM11710-49
<b>B3-1 Mainshaft Pilot Bearing Cup</b>			
Timken #LM11710			LM11710
<b>B3-2 Mainshaft Pilot Bearing Cone</b>			
Timken #LM11749			LM11749
<b>B4 Maindrive Gear</b>			
L21-s25(30)T: 4 cylinder T'bird	(1985-86)	E5ZZ-7017A	13-52-085-017
L22-s25(30)T: 4 cylinder Mustang	(1985-86)	E5ZZ-7017C	13-52-085-026
L19-s25(30)T: 4 cylinder	(1987-93)	E7ZZ-7017A	13-52-085-038
L24-s25(30)T: 8 cylinder 2.95 low		M-7017B	13-52-085-020
L23-s25(30)T: 8 cylinder 3.35 low	(1985-93)	E5ZZ-7017B	13-52-085-025
L23-s25(30)T: all	(1994-03)	F4ZZ-7017A	13-52-085-052
CSC	(2004- )	4R3Z-7017A	TTFM 4757
<i>NOTE: These SEVEN (7) maindrives used with roller bearing mainshaft pilot.</i>			
L24-s25(30)T: 8 cylinder 2.95 low			13-52-085-060
L23-s25(30)T: 8 cylinder 3.35 low	(1993)	F3ZZ-7017A	13-52-085-050
L23-s25(30)T: all	(1994-95)	F4ZZ-7017B	13-52-085-055
<i>NOTE: These THREE (3) maindrives used with tapered bearing mainshaft pilot.</i>			
<b>B5 Maindrive Bearing Assy</b>			
Timken #M88010-M88048			M88010-48
Timken #LM48510-LM48548			LM48510-48
<b>B5-1 Maindrive Bearing Cup</b>			
Timken #M88010		NSS	M88010
Timken #LM48510			LM48510
<b>B5-2 Maindrive Bearing Cone</b>			
Timken #M88048		NSS	M88048
Timken #LM48548			LM48548
<b>B6 Maindrive Bearing Shims: used with M88010-48 bearing</b>			
.012	as req.		13-52-037-070
.014	as req.		13-52-037-071
.016	as req.		13-52-037-072
.018	as req.		13-52-037-073
.020	as req.		13-52-037-074
.022	as req.		13-52-037-075
.023	as req.		13-52-037-076

**WARNER GEAR T5wc 5 Speed: FORD**

.024	as req.	13-52-037-077
.025	as req.	13-52-037-078
.026	as req.	13-52-037-079
.027	as req.	13-52-037-080
.028	as req.	13-52-037-081
.029	as req.	13-52-037-082
.030	as req.	13-52-037-083
.031	as req.	13-52-037-084
.032	as req.	13-52-037-085
.033	as req.	13-52-037-086
.034	as req.	13-52-037-087
.035	as req.	13-52-037-088
.036	as req.	13-52-037-089
.037	as req.	13-52-037-090
.038	as req.	13-52-037-091
.039	as req.	13-52-037-092
.040	as req.	13-52-037-093
.041	as req.	13-52-037-094
.042	as req.	13-52-037-095
.043	as req.	13-52-037-096
.044	as req.	13-52-037-097

**B6 Maindrive Bearing Shims: used with LM48510-LM48548 bearing**

.012	as req.	13-51-037-004
.014	as req.	13-51-037-001
.016	as req.	13-51-037-002
.018	as req.	13-51-037-003
.020	as req.	13-51-037-005
.022	as req.	13-51-037-007
.023	as req.	13-51-037-008
.024	as req.	13-51-037-009
.025	as req.	13-51-037-010
.026	as req.	13-51-037-011
.027	as req.	13-51-037-012
.028	as req.	13-51-037-013
.029	as req.	13-51-037-014
.030	as req.	13-51-037-015
.031	as req.	13-51-037-016
.032	as req.	13-51-037-017
.033	as req.	13-51-037-018
.034	as req.	13-51-037-019
.035	as req.	13-51-037-020
.036	as req.	13-51-037-006
.037	as req.	13-51-037-021
.038	as req.	13-51-037-022
.039	as req.	13-51-037-023
.040	as req.	13-51-037-024
.041	as req.	13-51-037-025
.042	as req.	13-51-037-026
.043	as req.	13-51-037-027
.044	as req.	13-51-037-028

# WARNER GEAR T5wc 5 Speed: FORD

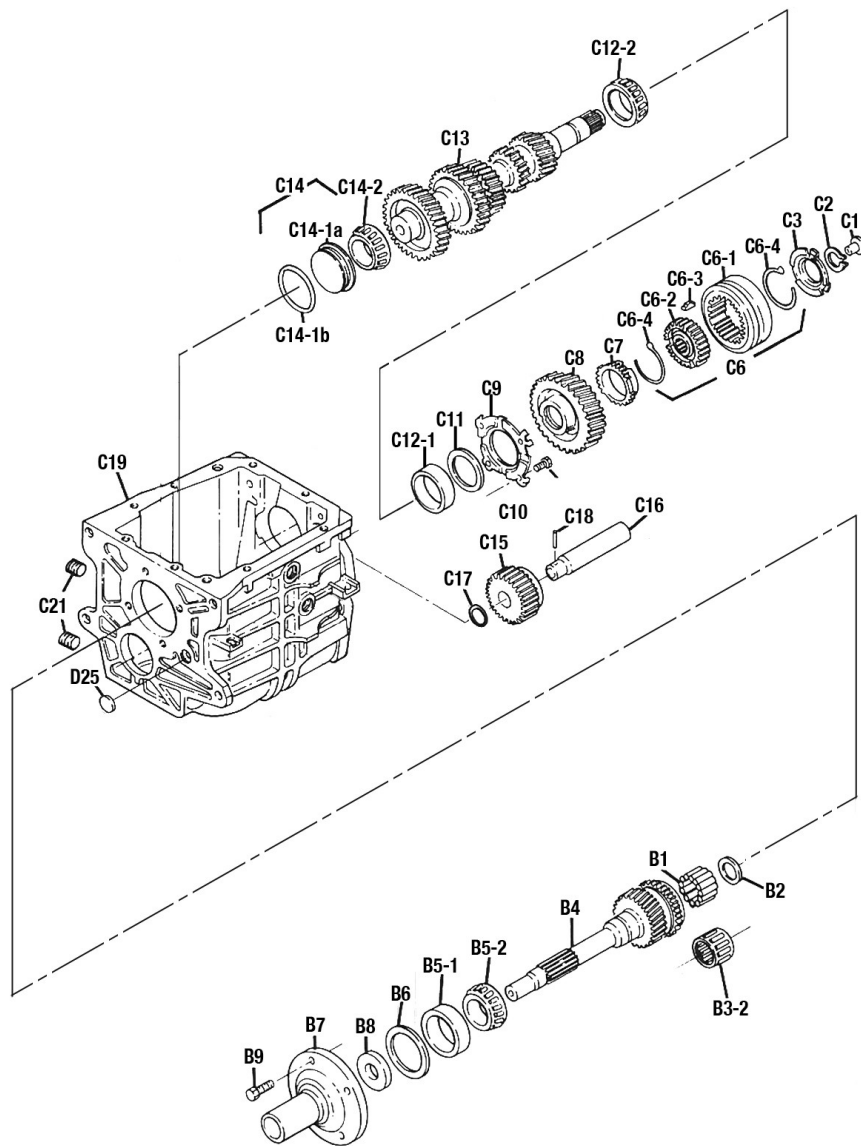

## WARNER GEAR T5wc 5 Speed: FORD

<b>B7</b>	<b>Maindrive Retainer (Assy)</b>			
	#13-52-027-919: 4 cylinder	(1987-93)	E7ZZ-7050A	13-52-027-019
	#13-52-027-908: except above	(1985-93)	E3ZZ-7050A	13-52-027-008
	#13-52-027-928: steel tube	(1985-93)	F0ZZ-7050A	13-52-527-002
	#13-52-027-928: steel tube	(1994-95)	F0ZZ-7050B	13-52-527-001
	slip yoke	(1999-03)	XR3Z-7050AA	13-52-527-005
	CSC	(2004- )	4R3Z-7050BA	TTEP 2160
<b>B7-1</b>	<b>Maindrive Retainer Flange</b>			
	steel tube design		NSS	NSS
<b>B7-2</b>	<b>Maindrive Retainer Tube</b>			
	steel tube design		NSS	NSS
<b>B7-3</b>	<b>Maindrive Retainer O-Ring</b>			
	steel tube design		NSS	NSS
<b>B8</b>	<b>Maindrive Oilseal</b>			
	rubber case		E9TZ-7052A	13-00-044-015
	all			TTSJ 1730
	<i>NOTE: Rubber case seals are problematic. For service we prefer a steel case design, Chicago Rawhide #12363.</i>			
<b>B9</b>	<b>Maindrive Retainer Fasteners</b>			
	all	req. 4	E805603S	13-00-183-009
<b>B10</b>	<b>Clutch Housing</b>			
	CSC	(2004- )	4R3Z-7505BA	TTCM 2109
	<i>NOTE: 'CSC' abbreviates 'Concentric (Clutch) Slave Cylinder'; 'RSC' abbreviates 'Remote (Clutch Slave Cylinder)'.</i>			
<b>B11</b>	<b>Clutch Housing Adapter Fasteners</b>			
	all	req. 12	(2004- )	F6ZZ-7A771A
				13-81-183-001
<b>B12</b>	<b>Clutch Release Fork Pivot</b>			
	all		F6ZZ-7B602A	13-81-146-001
<b>B13</b>	<b>Clutch Release Fork Pivot Lockwasher</b>			
	all		F6ZZ-7C208A	13-81-050-001
<b>B14</b>	<b>Concentric Slave Cylinder (CSC) Assy</b>			
	CSC	(2004- )		TCEP 2276
<b>B15</b>	<b>Concentric Slave Cylinder (CSC) Fasteners</b>			
	CSC	req. 2	(2004- )	13-86-183-007

## GROUP C: COUNTERSHAFTS AND CASE

<b>C1</b>	<b>Countershaft Oil Funnel</b>			
	all		E5ZZ-7L276A	13-52-034-002
<b>C2</b>	<b>Countershaft 5<sup>th</sup> Synchronizer Snapping</b>			
	all		E5ZZ-7059A	13-00-139-001
<b>C3</b>	<b>Countershaft 5<sup>th</sup> Synchronizer Retainer</b>			
	w/o reverse brake	(1985-91)	E5ZZ-7C396A	13-52-040-004
<b>C4</b>	<b>Countershaft Reverse Brake Cone</b>			
	w/ reverse brake	(1992- )	F2ZZ-7M000A	13-52-025-003

## WARNER GEAR T5wc 5 Speed: FORD

C5	Countershaft Reverse Brake Washer w/ reverse brake	(1992-95)	F2ZZ-7G042A	13-52-193-006
C6	Countershaft 5 <sup>th</sup> Synchronizer Assy w/o reverse brake	(1985-91)	E5ZZ-7124B	13-52-590-015
	w/ reverse brake	(1992-95)	F2ZZ-7124A	13-52-590-020
	w/ reverse brake	(2004- )	E5ZZ-7124B	13-52-590-015
C6-1	Clutch all		NSS	NSS
C6-2	Hub all		NSS	NSS
C6-3	Strut all	req. 3	D4ZZ-7A044A	13-32-093-002
C6-4	Spring all	req. 2	D4ZZ-7109A	13-32-156-002
C7	Countershaft 5 <sup>th</sup> /Reverse Synchronizer Ring s18(27)T: w/o brake	req.1	D4ZZ-7107B	13-32-091-002
	s18(27)T: w/ brake	req.2	D4ZZ-7107B	13-32-091-002
C8	Countershaft 5 <sup>th</sup> Gear R59-s27T: 4 cylinder T'bird	(1985-86)	E7ZZ-7144A	13-52-080-114
	R51-s27T: 4 cylinder Mustang	(1985-86)	E5ZZ-7144A	13-52-080-051
	R59-s27T: 4 cylinder	(1987-93)	E7ZZ-7144A	13-52-080-114
	R51-s27T: 6 cylinder	(1994-03)	F4ZZ-7144A	13-52-080-051
	R53-s27T: 6 cylinder	(2004- )		13-52-080-163
	R53-s27T: 8 cylinder 2.95 low			13-52-080-074
	R59-s27T: 8 cylinder 3.35 low	(1985-95)	E7ZZ-7144A	13-52-080-114
C9	Countershaft Rear Bearing Retainer all		E5ZZ-7195A	13-52-027-015
C10	Countershaft Rear Bearing Retainer Fasteners all	req.4	E5ZZ-7C210A	13-00-183-002
C11	Countershaft Rear Bearing Shims			
	.1005	as req.		13-52-037-034
	.102	as req.		13-52-037-035
	.1035	as req.		13-52-037-036
	.105	as req.		13-52-037-037
	.1065	as req.		13-52-037-038
	.108	as req.		13-52-037-039
	.1095	as req.		13-52-037-040
	.111	as req.		13-52-037-041
	.1125	as req.		13-52-037-042
	.114	as req.		13-52-037-043
	.1155	as req.		13-52-037-044
	.117	as req.		13-52-037-045
	.1185	as req.		13-52-037-046
	.120	as req.		13-52-037-047
	.1215	as req.		13-52-037-048
	.123	as req.		13-52-037-049
	.1245	as req.		13-52-037-050
	.126	as req.		13-52-037-051
	.1275	as req.		13-52-037-052
	.129	as req.		13-52-037-053

## WARNER GEAR T5wc 5 Speed: FORD

.1305	as req.		13-52-037-054
.132	as req.		13-52-037-055
.1335	as req.		13-52-037-056
.135	as req.		13-52-037-057
.1365	as req.		13-52-037-058
.138	as req.		13-52-037-059
.1395	as req.		13-52-037-060
.141	as req.		13-52-037-061
.1425	as req.		13-52-037-062
.144	as req.		13-52-037-063
.1455	as req.		13-52-037-064
.147	as req.		13-52-037-065
.1485	as req.		13-52-037-066
.150	as req.		13-52-077-067
.1515	as req.		13-52-037-068
.153	as req.		13-52-037-069
<b>C12</b>	<b>Countershaft Rear Bearing Assy</b>		
	Timken #LM67010-LM67048		LM67010-48
<b>C12-1</b>	<b>Countershaft Rear Bearing Cup</b>		
	Timken #LM67010		10-00-133-019
<b>C12-2</b>	<b>Countershaft Rear Bearing Cone</b>		
	Timken #LM67048		10-00-133-020
<b>C13</b>	<b>Countershaft Cluster Gear</b>		
	R33-31-23-S15-R14-s26T:4 cylinder	(1987-93)	E7ZZ-7113A
	R34-31-23-S15-R15-s26T: 6 cylinder	(1994-95)	F4ZZ-7113A
	R43-34-28-S15-R15-s26T: 6 cylinder		
	R34-29-23-S15-R15-s26T: 8 cylinder		F0ZZ-7113A
	R31-29-22-S15-R14-s26T: 8 cylinder		M-7113
	fixed yoke		13-52-077-048
	fixed yoke		13-52-077-052
			13-52-077-071
			13-52-077-068
			13-52-077-070
			13-52-077-071
			TTCF 7394
<b>C14</b>	<b>Countershaft Front Bearing Assy</b>		
	Timken #LM67010BCE-LM67048		TTKT 1693
<b>C14-1</b>	<b>Countershaft Front Bearing Cup Assy</b>		
	Timken #LM67010BCE		E5ZZ-7F431A
<b>C14-1a</b>	<b>Cup</b>		
	all		NSS
<b>C14-1b</b>	<b>O-Ring</b>		
	all		E5ZZ-7693A
<b>C14-2</b>	<b>Countershaft Front Bearing Cone</b>		
	Timken #LM67048		10-00-141-471
			10-00-133-020
<b>C15</b>	<b>Idler Gear Assy</b>		
	L20T		F2ZZ-7141A
<b>C15-1</b>	<b>Idler Gear</b>		
	all		NSS
<b>C15-2</b>	<b>Idler Gear Bushing</b>		
	all		T10-85A
<b>C16</b>	<b>Idler Shaft</b>		
	all		E3ZZ-7140A
			13-51-068-001
<b>C17</b>	<b>Idler Shaft O-Ring</b>		
	all		E3ZZ-7E397A
			10-00-141-211

## WARNER GEAR T5wc 5 Speed: FORD

C18	Idler Shaft Rollpin all		E3ZZ-7K381A	10-00-043-016
C19	Case Assy			
	#13-52-065-921: w/o reverse brake	(1985-91)	E5ZZ-7005A	13-52-565-023
	#13-52-065-921: w/ reverse brake	(1992-95)	F2ZZ-7005A	13-52-565-021
	RSC	(2003)		TTEP 1469
	CSC	(2004- )	4R3Z-7005BB	TTEP 2153
C19-1	Case all		NSS	NSS
C19-2	Magnet all		F5TZ-7E290A	4915
C19-3	Magnet Retainer all		385735S	13-32-149-003
C21	Filler/Drain Plug all	req. 2	F6ZZ-7A010A	13-00-052-007

## GROUP D: INTERNAL SHIFT LINKAGE

D1	1 <sup>st</sup> /2 <sup>nd</sup> Shift Fork all		E3ZZ-7230B	13-52-096-002
D2	1 <sup>st</sup> /2 <sup>nd</sup> Shift Fork Pad all	req. 2	D8ZZ-7L082A	13-52-127-008
D3	1 <sup>st</sup> /2 <sup>nd</sup> Shift Lugplate all		F2ZZ-7N232B	13-52-190-003
D4	3 <sup>rd</sup> /4 <sup>th</sup> Shift Fork all		E3ZZ-7230C	13-52-096-004
D5	3 <sup>rd</sup> /4 <sup>th</sup> Shift Fork Pad all	req. 2	D8ZZ-7L082A	13-52-127-008
D6	3 <sup>rd</sup> /4 <sup>th</sup> Shift Lugplate all		F2ZZ-7N232B	13-52-190-003
D7	Interlock all		E3ZZ-7K201A	13-52-014-004
D8	Selector Finger (Assy) assembled		E4ZZ-7302A	13-52-596-003
	cast		F7ZZ-7302AA	13-52-096-016
D8-1	Selector Lug assembled		NSS	NSS
D8-2	Selector Finger assembled		NSS	NSS
D9	Selector Finger Rollpin 3/16 x 13/16		305061S	13-32-043-004

# WARNER GEAR T5wc 5 Speed: FORD

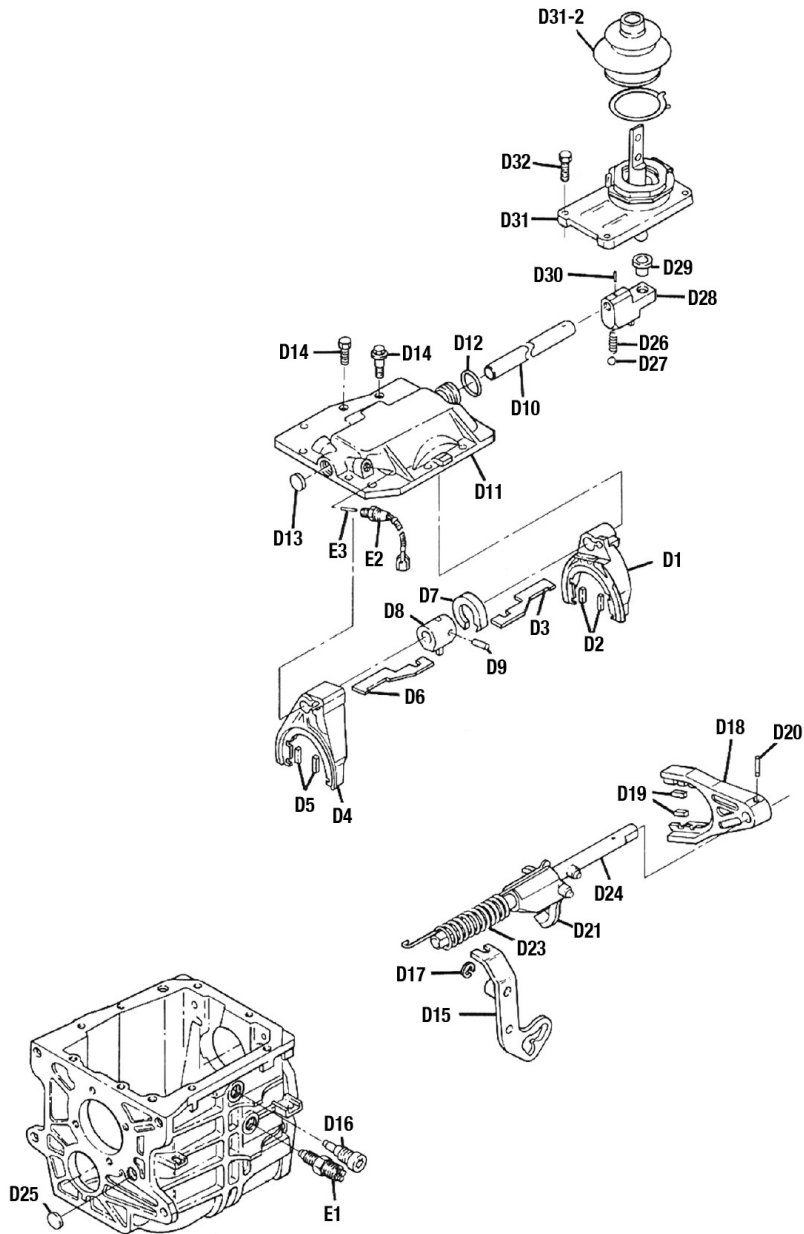

## WARNER GEAR T5wc 5 Speed: FORD

D10	Selector Rail slip yoke: w/o neutral start switch slip yoke: w/ neutral start switch fixed yoke:	(2004- )	E5ZZ-7358A E7ZZ-7358A 4R3Z-7240BA	13-52-100-015 13-52-100-023 TTBR 2170
D11	Shift Cover w/o neutral start switch w/ neutral start switch		F4ZZ-7222A E7ZZ-7222A	13-51-097-016 13-52-097-015
D12	Shift Cover O-Ring all		87038S	13-32-141-001
D13	Shift Cover Welsh Plug all			103892
D14	Shift Cover Fasteners dowel bolt bolt	req.2 req.8	N800037S2 N602167S2	13-32-183-006 13-32-183-009
D15	5 <sup>th</sup> /Reverse Shift Lever w/o reverse shift brake w/ reverse shift brake	(1985-91) (1992- )	E3ZZ-7K002A F2ZZ-7K002A	13-52-098-003 13-52-098-011
D16	5 <sup>th</sup> /Reverse Shift Lever Pivot all		E7TZ-7K024A	13-52-183-002
D17	5 <sup>th</sup> /Reverse Shift Lever C-Clip all		371197S	13-32-139-003
D18	5 <sup>th</sup> Shift Fork all		E3ZZ-7230D	13-52-096-014
D19	5 <sup>th</sup> Shift Fork Pad all all	req.2 req.2	D8ZZ-7L082A F4ZZ-7L082A	13-52-127-008 13-52-127-012
D20	5 <sup>th</sup> Shift Fork Rollpin 3/16 x 1		E3ZZ-7K381A	10-00-043-016
D21	Reverse Shift Fork Assy w/o reverse shift brake w/ reverse shift brake	(1985-91) (1992-95)	E3ZZ-7231A F2ZZ-7230A	13-52-596-009 13-52-596-013
D21-1	Reverse Shift Fork all		NSS	NSS
D21-2	Sector Roller all		E6TZ-7335A	13-52-127-001
D21-3	Sector Roller Pin w/o reverse shift brake w/ reverse shift brake	(1985-91) (1992-95)		13-52-043-005 13-52-043-010
D22	Reverse Shift Fork Spring Anchor w/ reverse shift brake	(1992-95)	F2ZZ-7N332A	13-52-183-003
D23	Reverse Shift Fork Spring w/o reverse shift brake w/ reverse shift brake	(1985-91) (1992-95)	E3ZZ-7K205A	13-52-156-005 13-52-156-023

## WARNER GEAR T5wc 5 Speed: FORD

D24	5 <sup>th</sup> /Reverse Shift Rail Assy all	E5ZZ-7240A	13-52-600-002
D24-1	5 <sup>th</sup> /Reverse Shift Rail all	NSS	NSS
D24-2	Sector Roller all	E6TZ-7335A	13-52-127-001
D24-3	Sector Roller Pin all		13-52-043-001
D25	5 <sup>th</sup> /Reverse Shift Rail Plug all		103892
D26	Detent Spring all	E3ZZ-7234B	13-51-156-001
D27	Detent Ball all		13-00-109-003
D28	Offset Lever all	E3ZZ-7F018A	13-51-098-006
D29	Offset Lever Bushing all	E3ZZ-7K453A	13-52-127-009
D30	Offset Lever Rollpin 3/16 x 1	E3ZZ-7K381A	10-00-043-016
D31	Shift Lever Assy all all	E5ZZ-7210A F4ZZ-7210B	13-52-598-065 13-52-598-107
D32	Shift Lever Fasteners M8 x 1.25	req. 4 E3ZZ-7A443A	13-51-183-001

## GROUP E: EXTERNAL ELECTROMECHANICALS

E1	Reverse Indicator Switch all TTET2071/6884	E0ZZ-15520A 6R3Z-15520AA	13-32-140-005 10-00-140-013
E2	Neutral Start Switch all		13-00-140-005
E3	Neutral Start Switch Pin all	E5ZZ-7C031A	10-00-043-020
E4	Speedometer Sensor Assy all	1R3Z-7H103AA	44-00-640-019
E5	Speedometer Sensor Fasteners screw		13-00-183-038